



规格书编号

SPEC NO :

# 产品规格书

# SPECIFICATION

CUSTOMER 客户: \_\_\_\_\_  
PRODUCT 产品: \_\_\_\_\_ SAW RESONATOR \_\_\_\_\_  
MODEL NO 型号: \_\_\_\_\_ R433M S6 \_\_\_\_\_  
PREPARED 编制: \_\_\_\_\_ CHECKED 审核: \_\_\_\_\_  
APPROVED 批准: \_\_\_\_\_ D A T E 日期: \_\_\_\_\_ 2011-6-20 \_\_\_\_\_

客户确认 CUSTOMER RECEIVED:		
审核 CHECKED	批准 APPROVED	日期 DATE

深圳市春宇无线有限公司  
CY Wireless Technology Limited





### 1. Scope

This specification shall cover the characteristics of 1-port SAW resonator with 433.92M used for remote-control security.

### 2. Electrical Specification

#### 2.1 Maximum Rating

DC Voltage VDC	10V
AC Voltage Vpp	10V 50Hz/60Hz
Operation temperature	-40°C to +85°C
Storage temperature	-45°C to +85°C
Source Power	0dBm

#### 2.2 Electronic Characteristics

Item	Unites	Minimum	Typical	Maximum
Center Frequency	MHz	433.845	433.920	433.995
Insertion Loss	dB		1.25	2.0
Quality Factor	Unload Q	12000	14000	
	50Ω Loaded Q	1000	2000	
Temperature Stability	Turnover Temperature	°C	10	25
	Freq.temp.Coefficient	ppm/°C	0.032	
Frequency Aging	ppm/yr		<±10	
DC. Insulation Resistance	MΩ	1.0		
RF Equivalent RLC Model	Motional Resistance R1	Ω	16	26
	Motional Inductance L1	μH	98.501	
	Motional Capacitance C1	fF	1.3658	
Transducer Static Capacitance C0	pF		1.5	

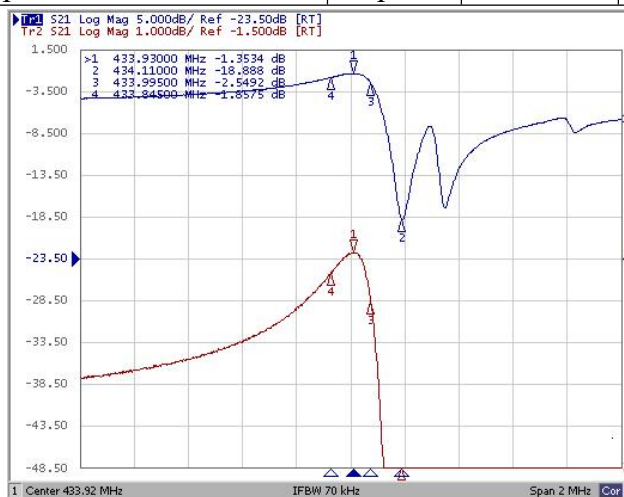

### 2.3 Equivalent LC Model

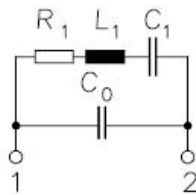

### 3. Test Circuit

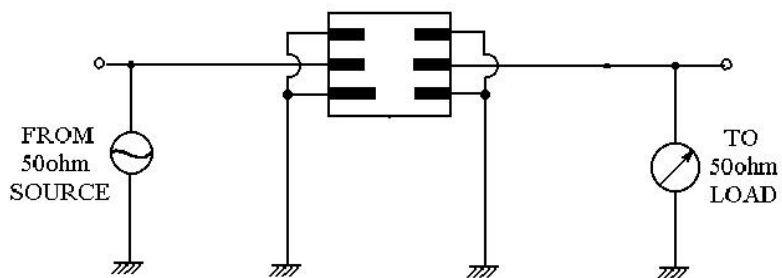

#### 4. Dimension

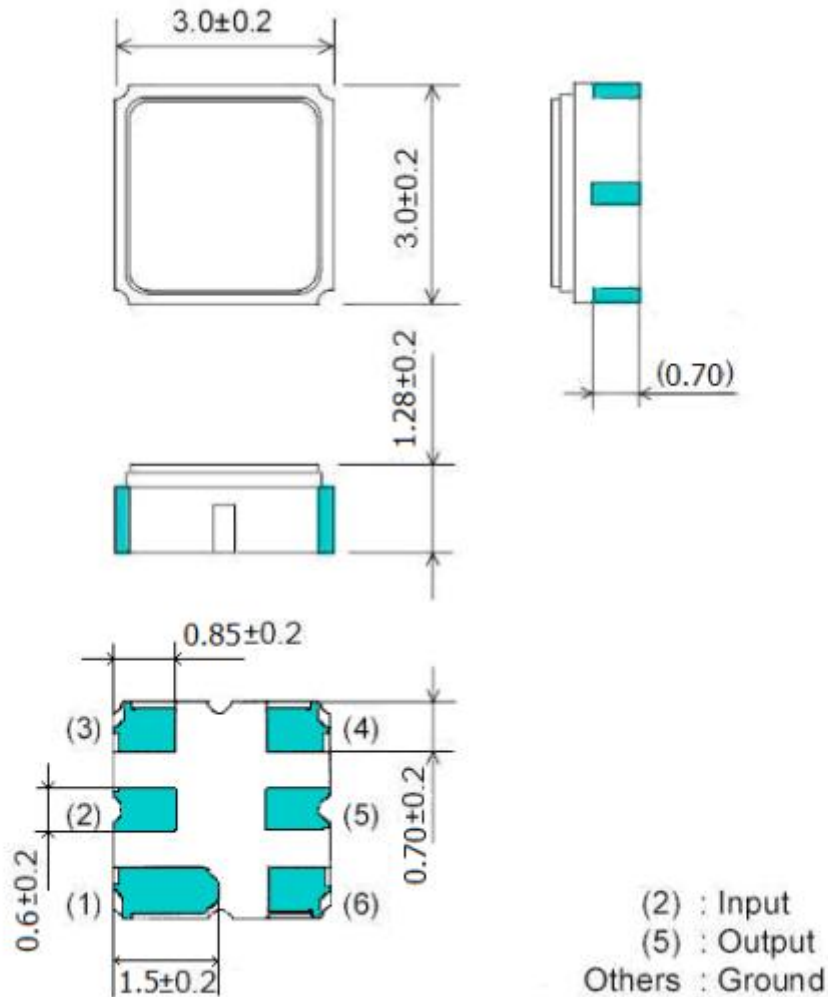

#### 5. Environment Characteristic

##### 5-1 Thermal Shock:

The components shall remain within the electrical specifications after being kept at the condition of heat cycle conditions:  $T_A = -40^\circ\text{C} \pm 3^\circ\text{C}$ ,  $T_B = 85^\circ\text{C} \pm 2^\circ\text{C}$ ,  $t_1 = t_2 = 30$  mins, switch time  $\leq 3$  mins & cycle time : 100 times, recovery time:  $2\text{h} \pm 0.5\text{h}$ .

##### 5-2 Resistance to solder heat

Submerge the device terminals into the solder bath at  $260^\circ\text{C} \pm 5^\circ\text{C}$  for  $10 \pm 1$  sec. Then release the device into the room conditions for 4 hours. It shall meet the specifications in 2.2.

##### 5-3 Solder ability



Submerge the device terminals into the solder bath at  $245^{\circ}\text{C} \pm 5^{\circ}\text{C}$  for 5s, More than 95% area of the soldering pad must be covered with new solder. It shall meet the specifications in 2.2

#### 5-4 The Temperature Storage:

5.4.1 High Temperature Storage: The components shall remain within the electrical specifications after being kept at the  $85^{\circ}\text{C} \pm 2^{\circ}\text{C}$  for 500 hours, recovery time :  $2\text{h} \pm 0.5\text{h}$ .

5.4.2 Low Temperature Storage: The components shall remain within the electrical specifications after being kept at the  $-40^{\circ}\text{C} \pm 3^{\circ}\text{C}$  for 500 hours, recovery time :  $2\text{h} \pm 0.5\text{h}$ .

#### 5-5 Humidity test:

The components shall remain within the electrical specifications after being kept at the condition of ambient temperature  $60^{\circ}\text{C} \pm 2^{\circ}\text{C}$ , and 90~96% RH for 500 hours.

#### 5-6 Mechanical shock

Drop the device randomly onto the concrete floor from the height of 1m for 3 times. The resonator shall fulfill the specifications in 2.2.

#### 5-7 Vibration

Subject the device to the vibration for 2 hour each in X, Y and Z axes with the amplitude of 1.5 mm at 10 to 55 Hz. The resonator shall fulfill the specifications in 2.2.

## 6. Remark

### 6.1 Static voltage

Static voltage between signal load & ground may cause deterioration & destruction of the component. Please avoid static voltage.

### 6.2 Ultrasonic cleaning

Ultrasonic vibration may cause deterioration & destruction of the component. Please avoid ultrasonic cleaning

### 6.3 Soldering

Only leads of component may be soldered. Please avoid soldering another part of component.

## 7. Packing

### 7.1 Dimensions

(1) Carrier Tape: Figure 1

(2) Reel: Figure 2

(3) The product shall be packed properly not to be damaged during transportation and storage.



7.2 Reeling Quantity

- 1000 pcs/reel 7"
- 3000 pcs/reel 13"

7.3 Taping Structure

(1) The tape shall be wound around the reel in the direction shown below.

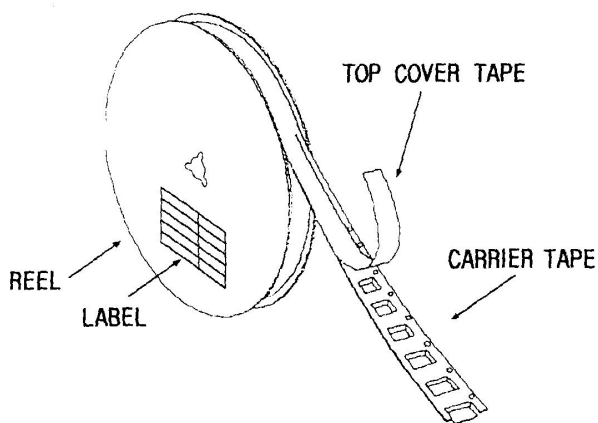

(2) Label

Device Name	
User Product Name	
Quantity	
Lot No.	

(3) Leader part and vacant position specifications.

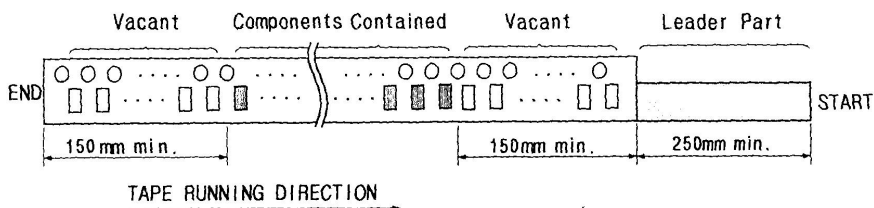

### 8. Tape Specifications

8.1 Tensile Strength of Carrier Tape: 4.4N/mm width

8.2 Top Cover Tape Adhesion (See the below figure)

- (1) pull off angle: 0~15°
- (2) speed: 300mm/min.
- (3) force: 20~70g

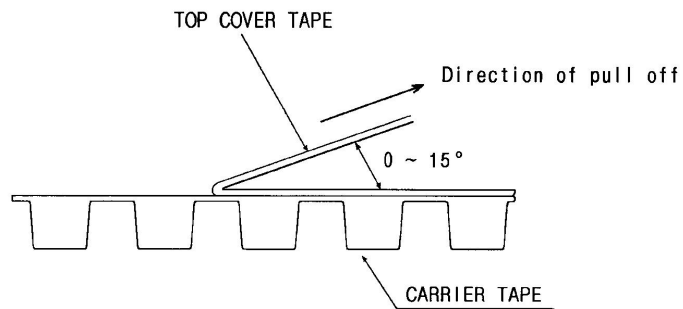

[Figure 1] Carrier Tape Dimensions

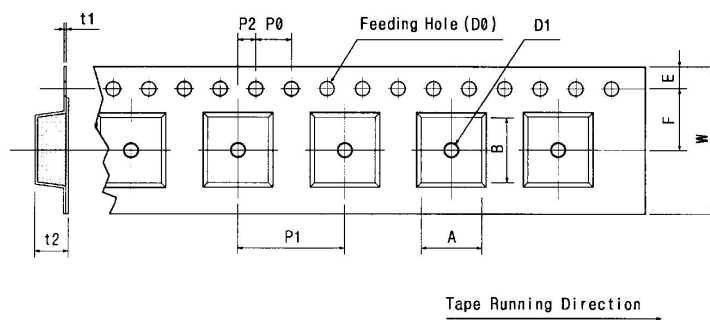

[Unit: mm]

W	F	E	P0	P1	P2	D0	D1	t1	t2	A	B
12.0± 0.3	5.5 ± 0.05	1.75± 0.1	4.0 ± 0.1	4.0 ± 0.1	2.0 ± 0.05	Ø1.5± 0.1	Ø1.0 ± 0.25	0.3 ± 0.05	1.25± 0.1	3.3± 0.1	3.3± 0.1

[Figure 2] Reel Dimensions

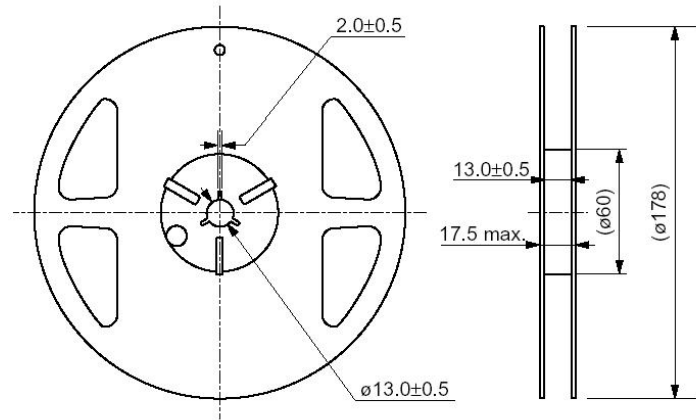

ø178 Reel Dimension

(in mm)

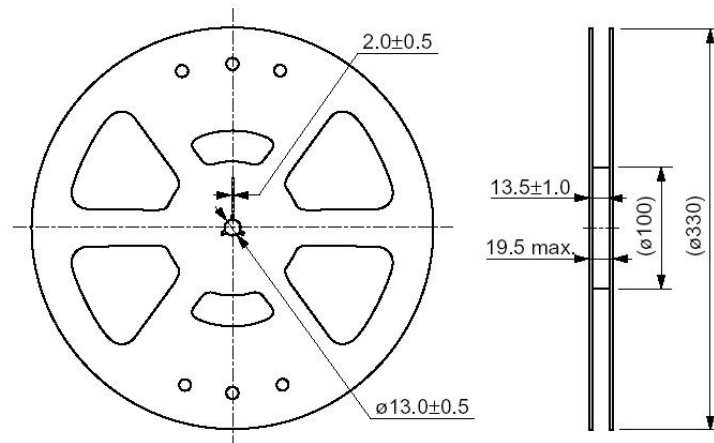

ø330 Reel Dimension

(in mm)