CY800/CY801 Datasheet

300M-450MHz ASK Receiver



General Description

The CY801 is a single chip ASK/OOK (ON-OFF Keyed) RF receiver IC. This device is a true “antenna-in to data-out” monolithic device. All RF and IF tuning are accomplished automatically within the IC which eliminates manual tuning and reduces production costs. The result is a highly reliable yet low cost solution.

The CY801 is a fully featured part in 16-pin packaging, the CY800 is the same part packaged in 8-pin packaging with a reduced feature set.

The CY801 provides two additional functions, (1) a Shutdown pin, which may be used to turn the device off for duty-cycled operation, and (2) a “Wake-up” output, which provides an output flag indicating when an RF signal is present. These features make the CY801 ideal for low and ultra-low power applications, such as RKE and remote controls.

All IF filtering and post-detection (demodulator) data filtering is provided within the CY801, so no external filters are necessary. One of four demodulator filter bandwidths may be selected externally by the user.

The CY801 offer fixed-mode (FIX) operation. In fixed mode the CY801 functions as a conventional super-heterodyne receiver, and fixed-mode provides better selectivity and sensitivity performance.

Features

- 300MHz to 450MHz frequency range
- High receiver sensitivity: -106dBm (315MHz), -107dBm (433MHz)
- Data-rate up to 10kbps
- Low Power Consumption
 - 3.0mA fully operational (315MHz)
 - 0.9μA in shutdown
 - 250μA in polled operation (10:1 duty-cycle)

CY800/CY801

- Wake-up output flag to enable decoders and microprocessors
- Very low RF re-radiation at the antenna
- Highly integrated with extremely low external part count

Applications

- Automotive Remote Keyless Entry (RKE)
- Remote controls
- Remote fan and light control
- Garage door and gate openers

Typical Application

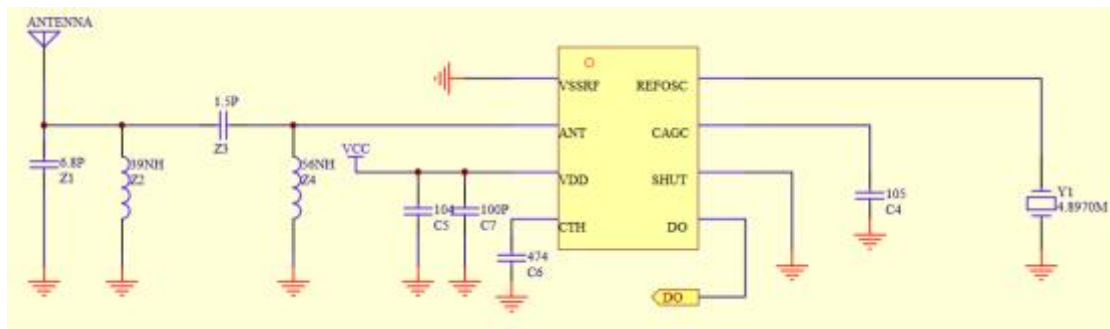

315MHz CY800

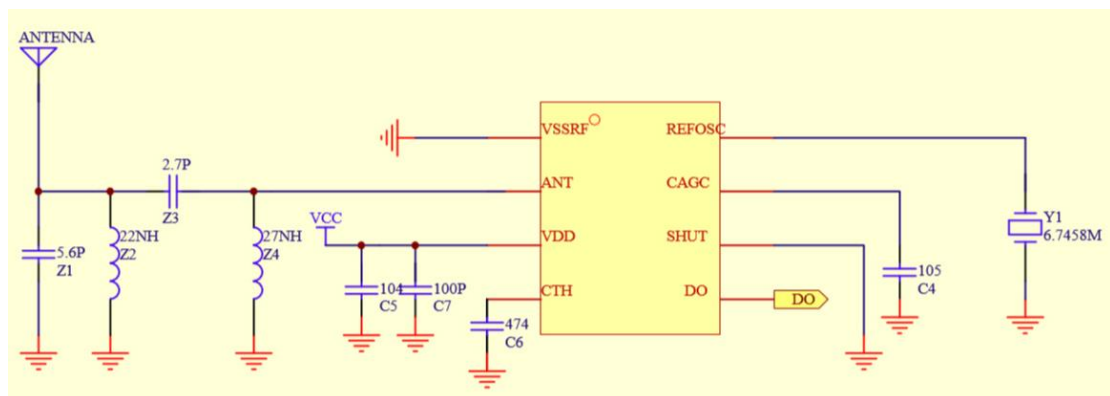

433MHz CY800

CY800/CY801

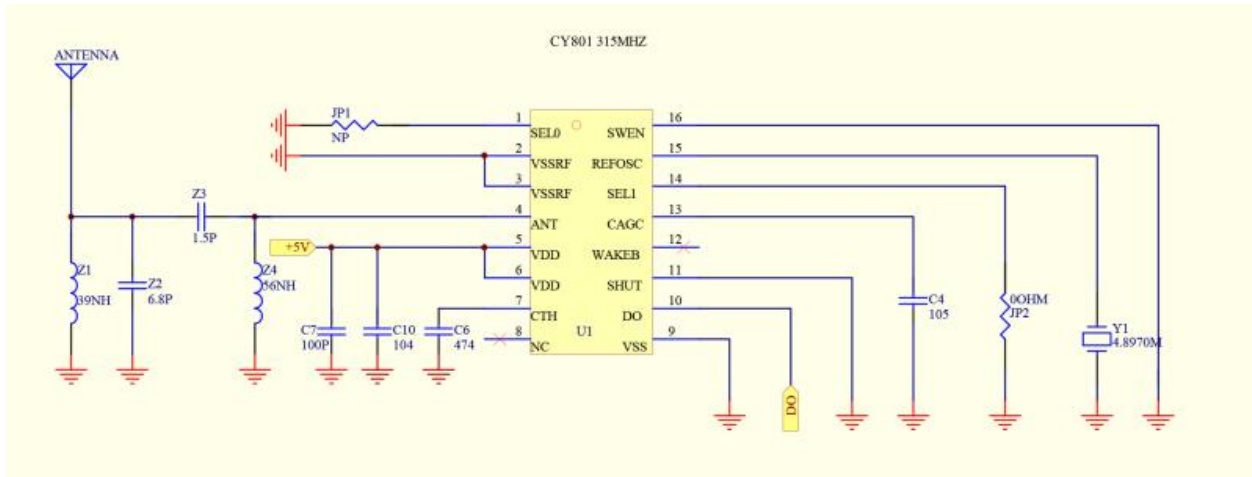

315MHz CY801

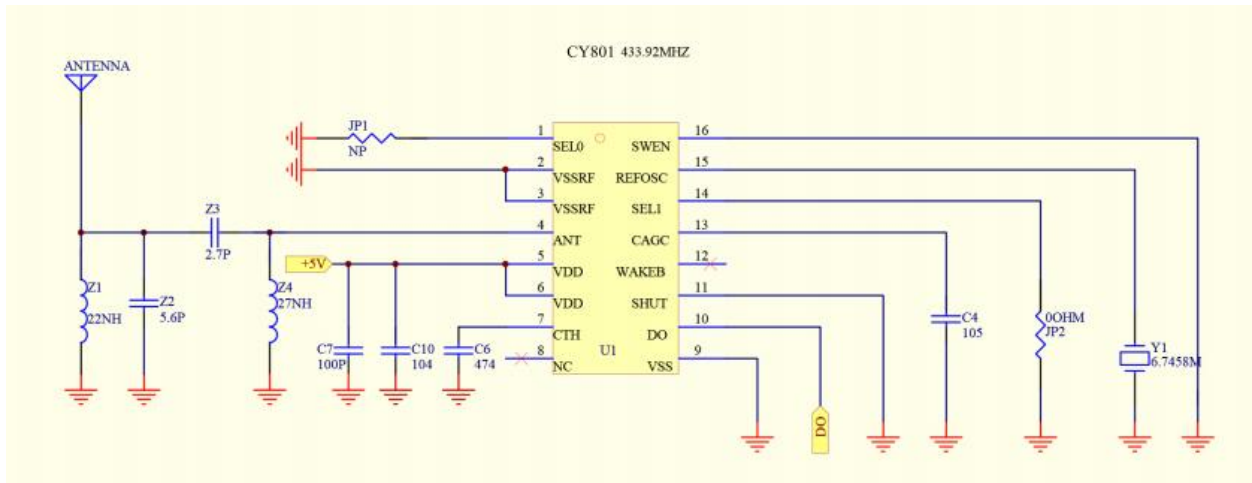

433MHz CY801

Ordering Information

Part Number	Demodulator Bandwidth	Operating Mode	Shut Down	WAKEB Output Flag	Package
CY800	2500Hz	Fixed	Yes	No	8-Pin SOP
CY801	User Programmable	Fixed or Sweep	Yes	Yes	16-Pin SOP

Pin Configuration

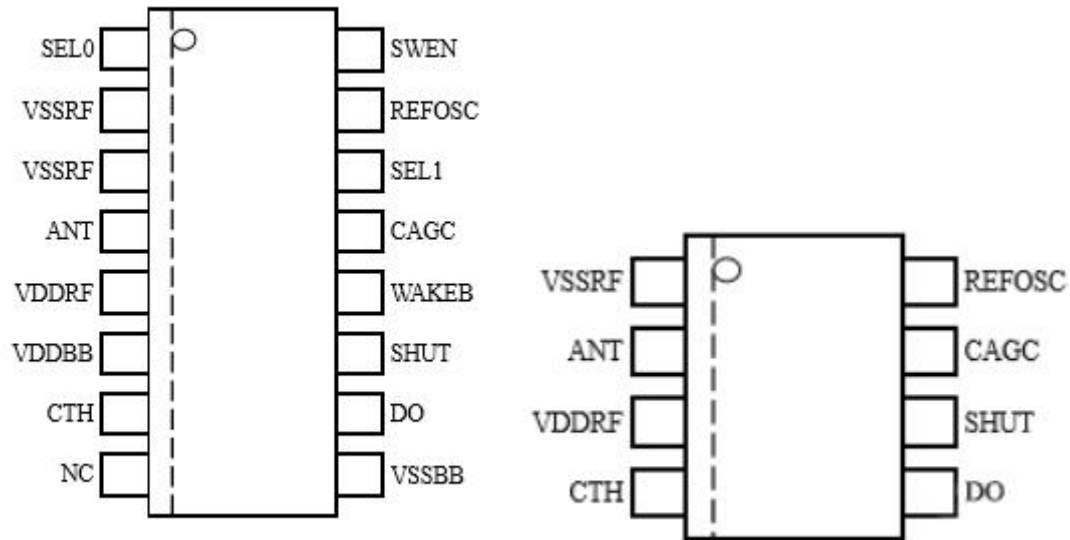

Standard 16-Pin or 8-Pin SOP (M) Packages

8-Pin Output

The standard 16-pin package allows complete control of all configurable features. Some reduced function 8-pin versions are also available.

For high-volume applications additional customized 8-pin devices can be produced. SWEN, SEL0 and SEL1 pins are internally bonded to reduce the pin count. Pin 6 may be configured as either SHUT or WAKEB.

SEL0	SEL1	Demodulator Bandwidth
1	1	10000Hz
0	1	5000Hz
1	0	2500Hz
0	0	1250Hz

Table 1. Nominal Demodulator Filter Bandwidth vs. SEL0, SEL1

Pin Description

Pin Number 16-Pin Pkg.	Pin Number 8-Pin Pkg.	Pin Name	Pin Function
1		SEL0	Bandwidth selection Bit 0 (Digital Input): Used in conjunction with SEL1 to set the desired demodulator filter bandwidth. See Table 1. Internally pulled-up to VDDRF
2,3	1	VSSRF	RF Power Supply: Ground return to the RF section power supply.
4	2	ANT	Antenna (Analog Input): For optional performance the ANT pin should be impedance matched to the antenna. See “Applications Information” for information on input impedance and matching techniques.
5	3	VDDRF	RF Power Supply: Positive supply input for the RF section of the IC.
6		VDDBB	Base-band power supply: positive supply input for the baseband section (digital section) of the IC.
7	4	CTH	Data slicing threshold capacitor (Analog I/O): capacitor connected to this pin extracts the dc average value from the demodulated waveform which becomes the reference for the internal data slicing comparator.
8		NC	Not internally connected
9		VSSBB	Base-Band Power Supply: Ground return to the baseband section power supply.
10	5	DO	Data Output (Digital Output)
11	6	SHUT	Shutdown (Digital Input): Shutdown-mode logic-level control input. Pull low to enable the receiver. Internally pulled-up to VDDRF
12		WAKEB	Wakeup (Digital Output): Active-low output that indicates detection of an incoming RF signal.
13	7	CAGC	Automatic Gain Control (Analog I/O): Connect an external capacitor to set the attack/ decay rate of the on-chip automatic gain control.
14		SEL1	Bandwidth Section Bit1 (Digital Input): Used in conjunction with SEL0 to set the desired demodulator filter bandwidth. See Table 1. Internally pulled-up to VDDRF.
15	8	RFFOSC	Reference Oscillator: Timing reference, sets the RF receive frequency.
16		SWEN	Sweep-Mode Enable (Digital Input): Sweep or fixed mode operation control input. SWEN high= sweep mode; SWEN low= conventional superheterodyne receiver. Internally pulled-up to VDDRF.

Absolute Maximum Ratings ⁽¹⁾

Supply Voltage (V_{DD})	+7V
Input/ Output Voltage (V_{IO})	$V_{SS}-0.3$ to $V_{DD}+0.3$
Junction Temperature (T_J)	+150°C
Storage Temperature Range (T_S)	-65°C to +150°C
Lead Temperature (soldering, 10 sec.)	+260°C
ESD Rating	Note 3

Operating Ratings ⁽²⁾

RF Frequency Range	300MHz to 440MHz
Supply Voltage (V_{DDRF} , V_{DDBB} , 300~370MHz)	+3.0V to +5.5V
Supply Voltage (V_{DDRF} , V_{DDBB} , 370~440MHz)	+3.3V to +5.5V
Data Duty-Cycle	20% to 80%
Reference Oscillator Input Range	0.1V _{PP} to 1.5V _{PP}
Ambient Temperature (T_A)	-30°C to +85°C

Electrical Characteristics

$V_{DDRF} = V_{DDBB} = V_{DD}$ where $+4.75V \leq V_{DD} \leq 5.5V$, $V_{SS} = 0V$; $C_{AGC} = 4.7\mu F$, $C_{TH} = 100nF$; $SEL0 = SEL1 = V_{SS}$; fixed mode ($SWEN = V_{SS}$); $f_{REFOSC} = 4.8970MHz$ (equivalent to $f_{RF} = 315MHz$); data-rate = 1kbps (Manchester encoded). $T_A = 25^\circ C$, bold values indicate $-40^\circ C \leq T_A \leq +85^\circ C$; current flow into device pins is positive; unless noted.

Symbol	Parameter	Condition	Min	Typ	Max	Units
I_{OP}	Operating Current	continuous operation, $f_{RF} = 315MHz$		3		mA
		polled with 10:1 duty cycle, $f_{RF} = 315MHz$		300		μA

CY800/CY801

		continuous operation, $f_{RF} = 433.92\text{MHz}$		4.8		mA
		polled with 10:1 duty cycle, $f_{RF} = 433.92\text{MHz}$		480		μA
I_{STBY}	Standby Current	$V_{SHUT} = V_{DD}$		0.9		μA

RF Section, IF Section

	Receiver Sensitivity ⁽⁴⁾	$f_{RF} = 315\text{MHz}$		-106		dBm
		$f_{RF} = 433.92\text{MHz}$		-107		dBm
f_{IF}	IF Center Frequency	Note 6		0.86		MHz
f_{BW}	IF Bandwidth	Note 6		0.43		MHz
	Maximum Receiver Input	$R_{SC} = 50\Omega$		-20		dBm
	Spurious Reverse Isolation	ANT pin, $R_{SC} = 50\Omega$, Note 5		30		μV_{rms}
	AGC Attack to Decay Ratio	$t_{ATTACK} \div t_{DECAY}$		0.1		
	AGC Leakage Current	$T_A = +85^\circ\text{C}$		± 100		nA

Reference Oscillator

Z_{REFOSC}	Reference Oscillator Input Impedance	Note 8		290		k Ω
	Reference Oscillator Source Current			5.2		μA

Demodulator

Z_{CTH}	CTH Source Impedance	Note 7		145		k Ω
$I_{ZCTH(leak)}$	CTH Leakage Current	$T_A = +85^\circ\text{C}$		± 100		nA
	Demodulator Filter Bandwidth	$V_{SEL0} = V_{DD}$, $V_{SEL1} = V_{DD}$		8000		Hz
	Sweep Mode	$V_{SEL0} = V_{SS}$, $V_{SEL1} = V_{DD}$		4000		Hz
	(SWEN = V_{DD} or OPEN)	$V_{SEL0} = V_{DD}$, $V_{SEL1} = V_{SS}$		2000		Hz
	Note 6	$V_{SEL0} = V_{SS}$, $V_{SEL1} = V_{SS}$		1000		Hz

Digital/ Control Section

$V_{IN(high)}$	Input-High Voltage	SEL0, SEL1,			0.8	V_{DD}
$V_{IN(low)}$	Input-Low Voltage	SEL0, SEL1,	0.2			V_{DD}

CY800/CY801

I_{OUT}	Output Current	DO, WAKEB pins, push-pull		10		μA
$V_{OUT(high)}$	Output High Voltage	DO, WAKEB pins, $I_{OUT} = -1\mu A$	0.9			V_{DD}
$V_{OUT(low)}$	Output Low Voltage	DO, WAKEB pins, $I_{OUT} = +1\mu A$			0.1	V_{DD}
t_R, t_F	Output Rise and Fall Times	DO, WAKEB pins, $C_{LOAD} = 15pF$		10		μs

Note:

- 1: Exceeding the absolute maximum rating may damage the device.
- 2: The device is not guaranteed to function outside its operating rating.
- 3: Devices are ESD sensitive, use appropriate ESD precautions. Meets class 1 ESD test requirements, (human body model HBM), in accordance with MIL-STD-883C, method 3015. Do not operate or store near strong electrostatic fields.
- 4: Sensitivity is defined as the average signal level measured at the input necessary to achieve 10^{-2} BER (bit error rate). The RF input is assumed to be matched to 50Ω .
- 5: Spurious reverse isolation represents the spurious components which appear on the RF input pin (ANT) measured into 50Ω with an input RF matching network.
- 6: Parameter scales linearly with reference oscillator frequency f_T . For any reference oscillator frequency other than 4.8970MHz, compute new parameter value as the ratio:

$$\frac{f_{REFOSC}MHz}{4.8970MHz} \times (\text{parameter value at } 4.8970MHz)$$

- 7: Parameter scales inversely with reference oscillator frequency f_T . For any reference oscillator frequency other than 4.8970MHz, compute new parameter value as the ratio:

$$\frac{4.8970MHz}{f_{REFOSC}MHz} \times (\text{parameter value at } 4.8970MHz)$$

- 8: Series resistance of the resonator (ceramic resonator or crystal) should be minimized to the extent possible. In cases where the resonator series resistance is too great, the oscillator may oscillate at a diminished peak-to-peak level, or may fail to oscillate entirely. CY recommends that series resistances for ceramic resonators and crystals not exceed 50Ohms and 100Ohms respectively.

Functional Diagram

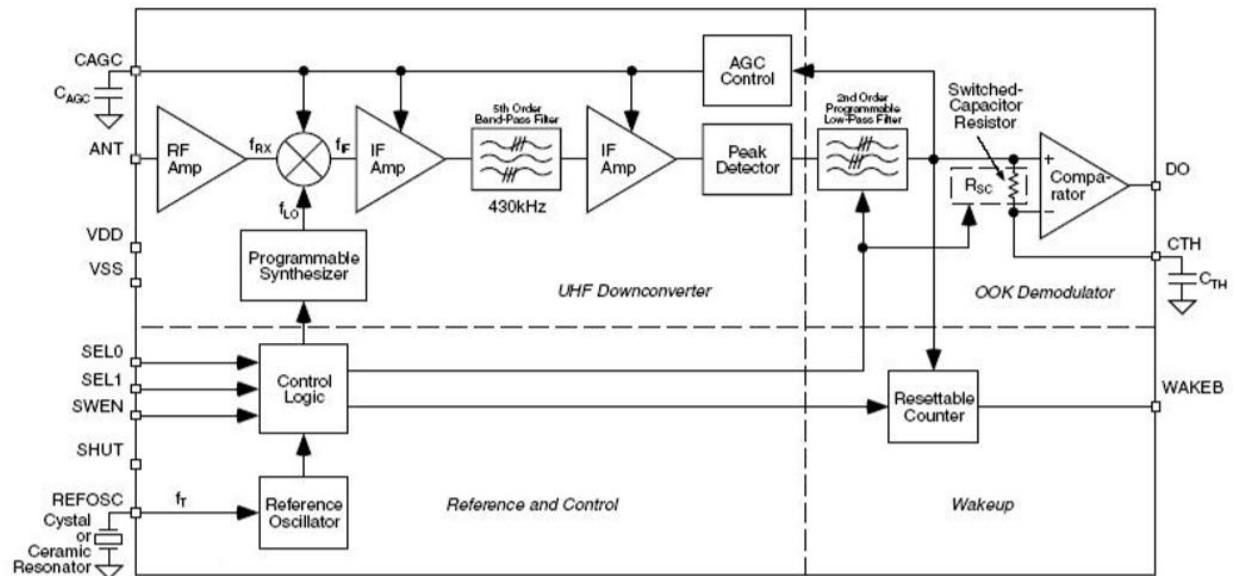

Figure 1. CY801 Block Diagram

Applications Information and Functional Description

Refer to figure 1 “CY801 Block Diagram”. Identified in the block diagram are the four sections of the IC: UHF Downconverter, OOK Demodulator, Reference and Control, and Wakeup. Also shown in the figure are two capacitors (CTH, CAGC) and one timing component, usually a crystal or ceramic resonator. With the exception of a supply decoupling capacitor, and antenna impedance matching network, these are the only external components needed by the CY801 to assemble a complete UHF receiver.

For optimal performance is highly recommended that the CY801 is impedance matched to the antenna, the matching network will add an additional two or three components.

Three control inputs are shown in the block diagram: SEL0, SEL1 and SHUT. Using these logic inputs, the user can control the operating mode and selectable features of the IC. These inputs are CMOS compatible, and are internally pulled-up for SEL0 and SEL1. IF Bandpass Filter Roll-off response of the IF Filter is 5th order, while the demodulator data filter exhibits a 2nd order response.

Design Steps

The following steps are the basic design steps for using the CY801 receiver:

- 1) Select the operating mode (sweep or fixed)
- 2) Select the reference oscillator
- 3) Select the CTH capacitor
- 4) Select the CAGC capacitor
- 5) Select the demodulator filter bandwidth

Step 1: Selecting the Operating Mode

Fixed-Mode Operation

For applications where the transmit frequency is accurately set (that is, applications where a SAW or crystal-based transmitter is used) the CY801 may be configured as a standard superheterodyne receiver (fixed mode). In fixed-mode operation the RF bandwidth is narrower making the receiver less susceptible to interfering signals.

Sweep-Mode Operation

Reserved mode for CY801, SWEN pin is not internally connected.

Step 2: Selecting the Reference Oscillator

All timing and tuning operations on the CY801 are derived from the internal Colpitts reference oscillator. Timing and tuning is controlled through the REFOSC pin in one of three ways:

- 1) Connect a ceramic resonator
- 2) Connect a crystal
- 3) Drive this pin with an external timing signal

The specific reference frequency required is related to the system transmit frequency.

Crystal or Ceramic Resonator Selection

Do not use resonators with integral capacitors since capacitors are included in the IC, also care should be taken to ensure low ESR capacitors are selected.

If operating in fixed-mode, a crystal is recommended. In sweep-mode either a crystal or ceramic resonator may be used. When a crystal or ceramic resonator is used the minimum voltage is 300mV_{PP} . If using an externally applied signal it should be AC-coupled and limited to the operating range of 0.1V_{PP} to 1.5V_{PP} .

Selecting Reference Oscillator Frequency f_T (Fixed Mode)

As with any superheterodyne receiver, the mixing between the internal LO (local oscillator) frequency f_{LO} and the incoming transmit frequency f_{TX} ideally must equal the IF center frequency. Equation 1 may be used to compute the appropriate f_{LO} for a given f_{TX} :

$$(1) f_{LO} = f_{TX} \pm \left(0.86 \frac{f_{TX}}{315} \right)$$

Frequencies f_{TX} and f_{LO} are in MHz. Note that two values of f_{LO} exist for any given f_{TX} , distinguished as “high-side mixing” and “low-side mixing.” High-side mixing results in an image frequency above the frequency of interest and low-side mixing results in a frequency below.

After choosing one of the two acceptable values of f_{LO} , use Equation 2 to compute the reference oscillator frequency f_T :

$$(2) f_T = \frac{f_{LO}}{64.5}$$

Frequency f_T is in MHz. Connect a crystal of frequency f_T to R_{EFOSC} on the CY801. Four-decimal-place accuracy on the frequency is generally adequate. The following table identifies f_T for some common transmit frequencies when the CY801 is operated in fixed mode.

Transmit Frequency (f_{TX})	Reference Oscillator Frequency (f_T)
315MHz	4.8970 MHz
390 MHz	6.0630 MHz
418 MHz	6.4983 MHz
433.92 MHz	6.7458 MHz

Table 2. Fixed Mode Recommended Reference Oscillator Values for Typical Transmit Frequencies (high-side mixing)

Step 3: Selecting the C_{TH} Capacitor

Extraction of the dc value of the demodulated signal for purposes of logic-level data slicing is accomplished using the external threshold capacitor C_{TH} and the on-chip switched-capacitor “resistor” R_{SC} , shown in the block diagram.

Slicing level time constant values vary somewhat with decoder type, data pattern, and

data rate, but typically values range from 5ms to 50ms. Optimization of the value of C_{TH} is required to maximize range.

Selecting Capacitor C_{TH}

The first step in the process is selection of a data-slicing-level time constant. This selection is strongly dependent on system issues including system decode response time and data code structure (that is, existence of data preamble, etc.). This issue is covered in more detail in Application Note 22.

The effective resistance of R_{SC} is listed in the electrical characteristics table as 145kΩ at 315MHz, this value scales linearly with frequency. Source impedance of the C_{TH} pin at other frequencies is given by equation (4), where f_T is in MHz:

$$(4) R_{SC} = 145k\Omega \frac{4.8970}{f_T}$$

τ of 5x the bit-rate is recommended. Assuming that a slicing level time constant τ has been established, capacitor C_{TH} may be computed using equation

$$(5) C_{TH} = \frac{\tau}{R_{SC}}$$

A standard $\pm 20\%$ X7R ceramic capacitor is generally sufficient.

Step 4: Selecting the C_{AGC} Capacitor

The signal path has AGC (automatic gain control) to increase input dynamic range. The attack time constant of the AGC is set externally by the value of the C_{AGC} capacitor connected to the C_{AGC} pin of the device. To maximize system range, it is important to keep the AGC control voltage ripple low, preferably under 10mV_{pp} once the control voltage has attained its quiescent value. For this reason capacitor values of at least 0.47μF are recommended.

The AGC control voltage is carefully managed on-chip to allow duty-cycle operation of the CY801. When the device is placed into shutdown mode (SHUT pin pulled high), the AGC capacitor floats to retain the voltage. When operation is resumed, only the voltage droop due to capacitor leakage must be replenished. A relatively low-leakage capacitor is recommended when the devices are used in duty-cycled operation.

To further enhance duty-cycled operation, the AGC push and pull currents are boosted for approximately 10ms immediately after the device is taken out of shutdown. This compensates for AGC capacitor voltage droop and reduces the time to restore the correct AGC voltage. The current is boosted by a factor of 45.

Selecting C_{AGC} Capacitor in Continuous Mode

A C_{AGC} capacitor in the range of $0.47\mu\text{F}$ to $4.7\mu\text{F}$ is typically recommended. The value of the C_{AGC} should be selected to minimize the ripple on the AGC control voltage by using a sufficiently large capacitor. However if the capacitor is too large the AGC may react too slowly to incoming signals. AGC settling time from a completely discharged (zero-volt) state is given approximately by Equation 6:

$$(6) \Delta t = 1.333C_{AGC} - 0.44$$

Where: C_{AGC} is in μF , and Δt is in seconds.

Selecting C_{AGC} Capacitor in Duty-Cycle Mode

Voltage droop across the C_{AGC} capacitor during shutdown should be replenished as quickly as possible after the IC is enabled. As mentioned above, the CY801 boosts the push-pull current by a factor of 45 immediately after start-up. This fixed time period is based on the reference oscillator frequency f_T . The time is 10.9ms for $f_T = 6.00\text{MHz}$, and varies inversely with f_T . The value of C_{AGC} capacitor and the duration of the shutdown time period should be selected such that the droop can be replenished within this 10ms period.

Polarity of the droop is unknown, meaning the AGC voltage could droop up or down. Worst-case from a recovery standpoint is downward droop, since the AGC pull-up current is 1/10th magnitude of the pulldown current. The downward droop is replenished according to the Equation 7:

$$(7) \frac{I}{C_{AGC}} = \frac{\Delta V}{\Delta t}$$

Where:

I = AGC pullup current for the initial 10ms ($67.5\mu\text{A}$)

C_{AGC} = AGC capacitor value

Δt = droop recovery time

ΔV = droop voltage

For example, if user desires $\Delta t = 10\text{ms}$ and chooses a $4.7\mu\text{F}$ C_{AGC} , then the allowable droop is about 144mV. Using the same equation with 200nA worst case pin leakage and assuming $1\mu\text{A}$ of capacitor leakage in the same direction, the maximum allowable Δt (shutdown time) is about 0.56s for droop recovery in 10ms.

The ratio of decay-to-attack time-constant is fixed at 10:1 (that is, the attack time constant is 1/10th of the decay time constant). Generally the design value of 10:1 is adequate for the vast majority of applications. If adjustment is required the constant may be varied by adding a resistor in parallel with the C_{AGC} capacitor. The value of the resistor must be determined on a case by case basis.

Step 5: Selecting the Demod Filter Bandwidth

The inputs SEL0 and SEL1 control the demodulator filter bandwidth in four binary steps (625Hz to 5000Hz in sweep, 1250Hz to 10000Hz in fixed mode), see Table 1. Bandwidth must be selected according to the application. The demodulator bandwidth should be set according to equation 8.

$$(8) \text{ Demodulator bandwidth} = 0.65 / \text{Shortest pulse-width}$$

It should be noted that the values indicated in table 1 are nominal values. The filter bandwidth scales linearly with frequency so the exact value will depend on the operating frequency. Refer to the “Electrical Characteristics” for the exact filter bandwidth at a chosen frequency.

SEL0	SEL1	Demodulator Bandwidth
		Fixed Code
1	1	10000Hz
0	1	5000Hz
1	0	2500Hz
0	0	1250Hz

Table 1. Nominal Demodulator Filter Bandwidth vs. SEL0, SEL1 and Operating Mode

Additional Applications Information

In addition to the basic operation of the CY801 the following enhancements can be made. In particular it is strongly recommended that the antenna impedance is matched to the input of the IC.

Antenna Impedance Matching

As shown in table 4 the antenna pin input impedance is frequency dependant.

The ANT pin can be matched to 50 Ohms with an L-type circuit. That is, a shunt inductor from the RF input to ground and another in series from the RF input to the antenna pin.

Inductor values may be different from table depending on PCB material, PCB thickness, ground configuration, and how long the traces are in the layout. Values shown were characterized for a 0.031 thickness, FR4 board, solid ground plane on bottom layer, and very short traces. MuRata and Coilcraft wire wound 0603 or 0805

CY800/CY801

surface mount inductors were tested, however any wire wound inductor with high SRF (self resonance frequency) should do the job.

Frequency (MHz)	$Z_{IN}()$ Z_{11}	S_{11}	$L_{SHUNT}(nH)$	$L_{SERIES}(nH)$
300	12-j166	0.803-j0.529	15	72
305	12-j165	0.800-j0.530	15	72
310	12-j163	0.796-j0.536	15	72
315	13-j162	0.791-j0.536	15	72
320	12-j160	0.789-j0.543	15	68
325	12-j157	0.782-j0.550	12	68
330	12-j155	0.778-j0.556	12	68
335	12-j152	0.770-j0.564	12	68
340	11-j150	0.767-j0.572	15	56
345	11-j148	0.762-j0.578	15	56
350	11-j145	0.753-j0.586	12	56
355	11-j143	0.748-j0.592	12	56
360	11-j141	0.742-j0.597	10	56
365	11-j139	0.735-j0.603	10	56
370	10-j137	0.732-j0.612	12	47
375	10-j135	0.725-j0.619	12	47
380	10-j133	0.718-j0.625	10	47
385	10-j131	0.711-j0.631	10	47
390	10-j130	0.707-j0.634	10	43
395	10-j128	0.692-j0.641	10	43
400	10-j126	0.692-j0.647	10	43
405	10-j124	0.684-j0.653	10	39
410	10-j122	0.675-j0.660	10	39
415	10-j120	0.667-j0.667	10	39
420	10-j118	0.658-j0.673	10	36
425	10-j117	0.653-j0.677	10	36
430	10-j115	0.643-j0.684	10	33
435	10-j114	0.638-j0.687	10	33

440	8-j112	0.635-j0.704	8.2	33
-----	--------	--------------	-----	----

Table 4. Input Impedance Versus Frequency

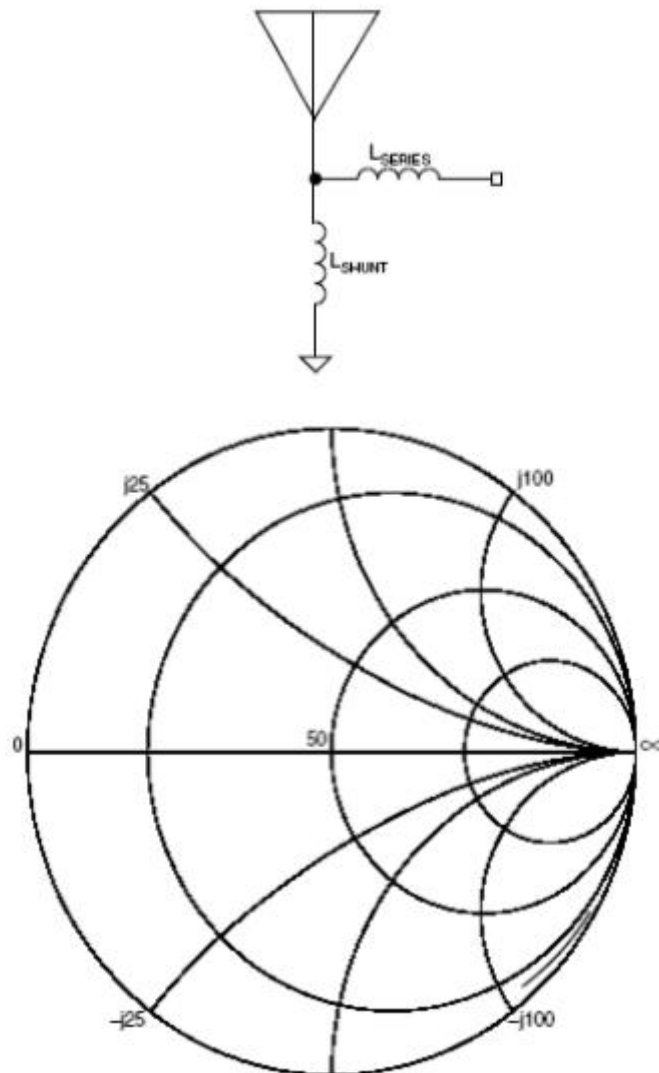

Shutdown Function

Duty-cycled operation of the CY801 (often referred to as polling) is achieved by turning the CY801 on and off via the SHUT pin. The shutdown function is controlled by a logic state applied to the SHUT pin. When VSHUT is high, the device goes into low-power standby mode.

Power Supply Bypass Capacitors

VDDBB and VDDRF should be connected together directly at the IC pins. Supply bypass capacitors are strongly recommended. They should be connected to VDDBB and VDDRF and should have the shortest possible lead lengths. For best performance, connect VSSRF to VSSBB at the power supply only (that is, keep V_{SSBB} currents from flowing through the V_{SSRF} return path).

Increasing Selectivity with an Optional BandPass Filter

For applications located in high ambient noise environments, a fixed value band-pass network may be connected between the ANT pin and VSSRF to provide additional receive selectivity and input overload protection. A minimum input configuration is included in figure 2a. it provides some filtering and necessary overload protection.

Data Squelching

During quiet periods (no signal) the data output (DO pin) transitions randomly with noise. Most decoders can discriminate between this random noise and actual data but for some system it does present a problem. There are three possible approaches to reducing this output noise:

- 1) Analog squelch to raise the demodulator threshold
- 2) Digital squelch to disable the output when data is not present
- 3) Output filter to filter the (high frequency) noise glitches on the data output pin.

The simplest solution is add analog squelch by introducing a small offset, or squelch voltage, on the CTH pin so that noise does not trigger the internal comparator. Usually 20mV to 30mV is sufficient, and may be achieved by connecting a several-megohm resistor from the CTH pin to either V_{SS} or V_{DD}, depending on the desired offset polarity. Since the CY801 has receiver AGC noise at the internal comparator input is always the same, set by the AGC. The squelch offset requirement does not change as the local noise strength changes from installation to installation. Introducing squelch will reduce sensitivity and also reduce range. Only introduce an amount of offset sufficient to quiet the output. Typical squelch resistor values range from 6.8MΩ to 10MΩ.

Wake-Up Function

The WAKEB output signal can be used to reduce system power consumption by enabling the rest of a system when an RF signal is present. The WAKEB is an output logic signal which goes active low when the IC detects a constant RF carrier. The wake-up function is unavailable when the IC is in shutdown mode.

To activate the Wake-Up function, a received constant RF carrier must be present for 128 counts or the internal system clock. The internal system clock is derived from the reference oscillator and is 1/256 the reference oscillator frequency. For example:

$$f_T = 6.4\text{MHz}$$

$$f_S = f_T/256 = 25\text{kHz}$$

$$P_S = 1/f_S = 0.04\text{ms}$$

$$128 \text{ counts} \times 0.04\text{ms} = 5.12\text{ms}$$

Where:

f_T = reference oscillator frequency

f_S = system clock frequency

P_S = system clock period

The Wake-Up counter will reset immediately after a detected RF carrier drops. The duration of the Wake-Up signal output is then determined by the required wake up time plus an additional RF carrier on time interval to create a wake up pulse output.

$$\text{WAKEB Output Pulse Time} = \text{TWAKE} + \text{Additional RF Carrier on Time}$$

For designers who wish to use the wakeup function while squelching the output, a positive squelching offset voltage must be used. This simply requires that the squelch resistor be connected to a voltage more positive than the quiescent voltage on the CTH pin so that the data output is low in absence of a transmission.

Applications Example

315MHz Receiver/Decoder Application

Figure 2a illustrates a typical application for the CY801 UHF Receiver IC. This receiver operates continuously (not duty cycled) in sweep mode, and features 6-bit address decoding and two output code bits.

Operation in this example is at 315MHz, and may be customized by selection of the appropriate frequency reference (Y1), and adjustment of the antenna length. The value of C4 would also change if the optional input filter is used. Changes from the 1kb/s data rate may require a change in the value of R1. A bill of materials accompanies the schematic.

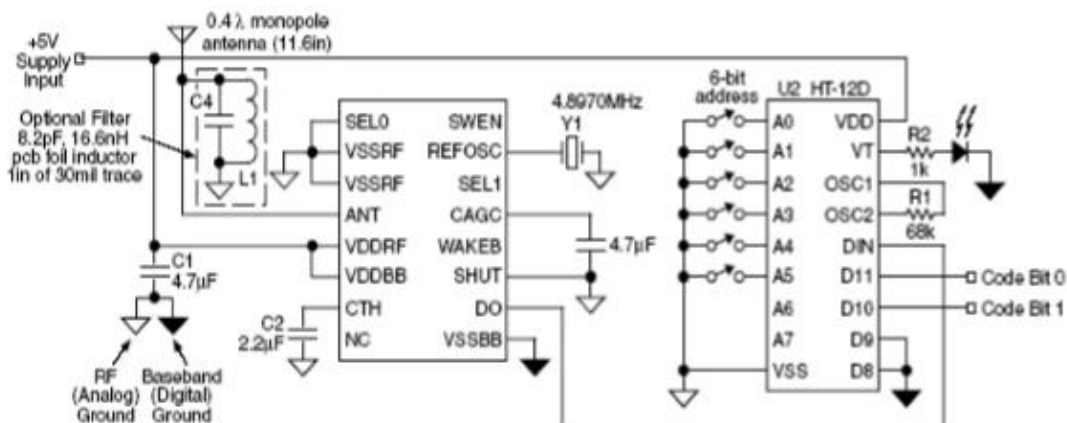

Figure 2a. 315MHz, 1kbps On-Off Keyed Receiver/Decoder

CY800/CY801

Item	Part Number	Manufacturer	Description
U1	CY801	CY	UHF Receiver
U2	HT-12D	Holtek	Logic Decoder
CR1	CSA6.00MG	Murata	6.00MHz Ceramic Resonator
D1	SSF-LX100LID	Lumex	Red LED
R1			68K 1/4W 5%
R2		Vishay	1K 1/4W 5%
C1		Vishay	4.7uF dipped tantalum capacitor
C2		Vishay	4.7uF dipped tantalum capacitor
C3		Vishay	2.2uF dipped tantalum capacitor
C4		Vishay	8.2pF COG ceramic capacitor

Figure 2b. Bill of Material

Package Information

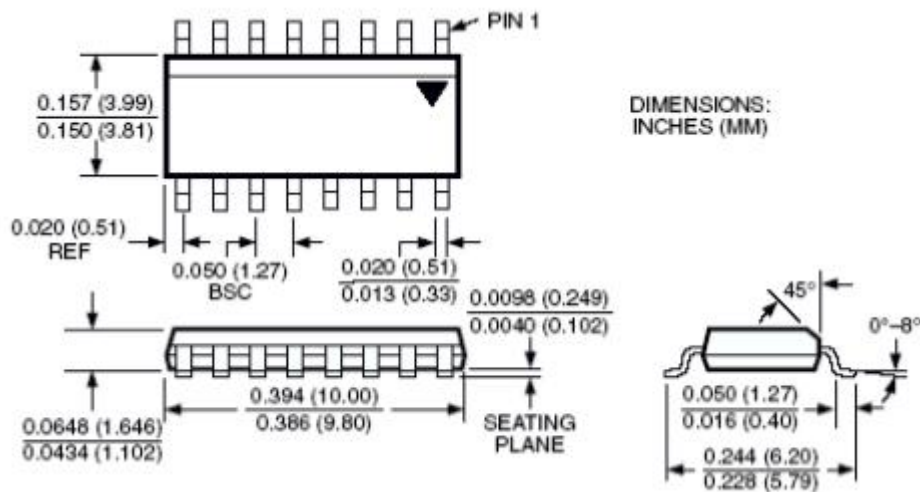

16-Pin SOP (M)

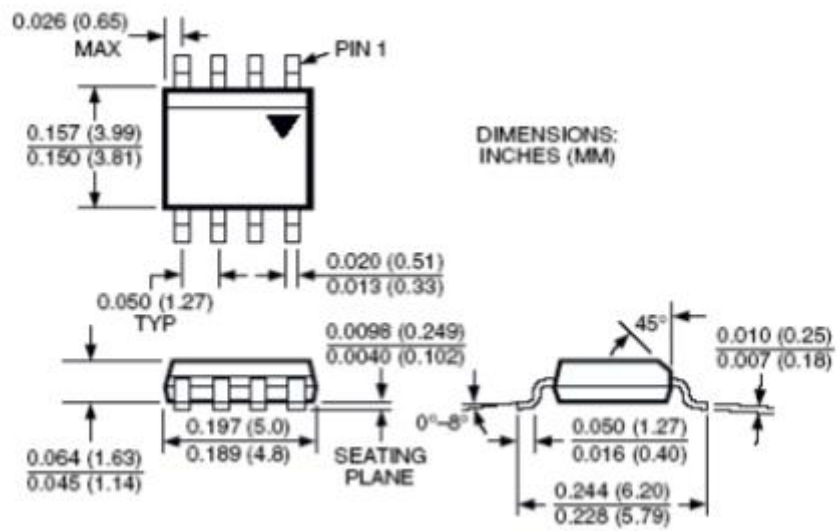

8-Pin SOP (M)